



Instruments That Advance The Art

Pixie-Net XL

Multi-Channel Desktop Digital Pulse Processor

FEATURES

- Compact standalone detector readout electronics.
- Embedded Linux platform
- On-board MCA spectra.
- Waveform capture and Pulse Shape Analysis.
- Local USB and SD storage.
- Web interface.
- 1 or 10 Gbps Ethernet output for list mode data.
- Optional White Rabbit IEEE 1588 time synchronization
- Sub-nanosecond Timing Resolution
- Desktop, rack mount, OEM



OVERVIEW

The Pixie-Net XL is a multi-channel digital pulse processor for radiation detectors in desktop format with integrated networking and USB resources. Designed for high-precision coincidence gamma-ray spectroscopy using HPGe detectors, scintillators, or silicon detectors, the Pixie-Net XL offers not only waveform digitization and capture but also pulse height measurements, on-board energy histograms, time stamping and constant fraction timing, pileup inspection, external gating and online pulse shape analysis. Besides nuclear spectroscopy, the Pixie-Net XL can be used for neutron/gamma discrimination, time-of-flight measurements, and coincidence/anti-coincidence measurements.

The Pixie-Net XL combines an embedded Linux system with XIA's digital pulse processing developed on the Pixie PXI spectrometer series. Incoming signals are digitized and processed in an FPGA with dedicated Ethernet interface, allowing processed data to be streamed out directly at rates of 1 or 10 Gbps. A Zynq processor board acts as an integrated data acquisition Linux PC for setup, control, web monitoring and managing local USB or SD card storage. Multiple units can synchronize clocks through 1588 IEEE PTP high accuracy (White Rabbit). The Pixie-Net XL is available in a variety of digitizing options, channel density, and input connector formats.

APPLICATIONS

- Scintillator, HPGe, Si detectors
- Real-time Pulse-Shape Discrimination
- Clover detectors
- Distributed Data Acquisition
- Homeland Security
- OEM systems
- Remote monitoring

XIA LLC

www.xia.com

sales@xia.com Tel: +1-510-401-5760
2744 East 11th St, Oakland, CA 94601 USA

ARCHITECTURE

Two ADC Daughtercard Slots, Each Capable of

- 8 channels, 14bit, 250 MHz, variable offset, fixed gain, 0.1" header input connectors
- 4 channels, 14bit, 125 MHz, variable offset, variable gain, SMB input connectors

(More ADC options under development)

Two Pulse Processing FPGAs With

- High speed LVDS I/O to daughtercard
- Dedicated SFP cage for 1 or 10 Gbps Ethernet (copper or optical)
- 4 Gbit DDR3 SDRAM
- Direct path of DAQ data from FPGA to remote storage
- List mode data output rates up to 500,000 events/s, 70 MB/s (1G) or 350 MB/s (10G)

Zynq “System on Chip” Platform acting as integrated DAQ PC

- Dual-core ARM® Cortex™-A9 with Xilinx 7-series FPGA section
- Gigabit Ethernet, 1GB RAM, USB2.0, 16 GB SD card storage
- Linux OS based on Ubuntu 18
- Local file storage and web server
- Open source software
- Used for DAQ setup, control and monitoring

Timing Performance

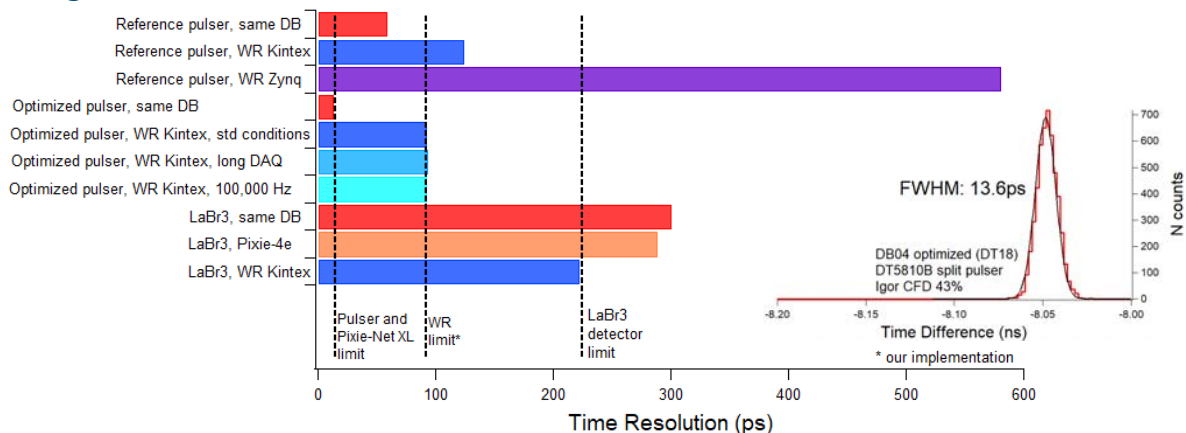

Summary of time resolution for split pulser and scintillator pair, same daughtercard or White Rabbit synchronization

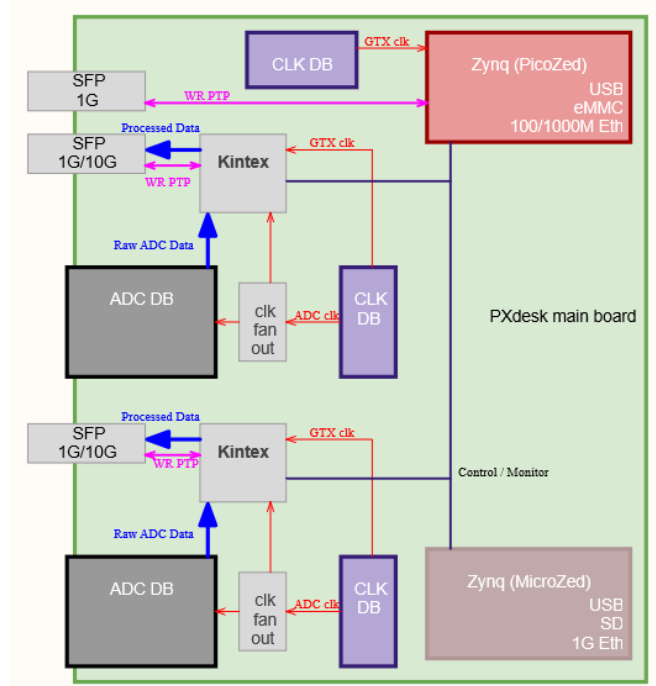

High Speed Data Flow: ADC ► FPGA ► Ethernet SFP

Network Time Synchronization

- 1G SFP optical Ethernet is compatible with White Rabbit timing protocol (IEEE 1588 PTP “high accuracy profile”)
- 1PPS out, clock in, clock out
- Synchronizes multiple units to < 100ps precision (time of flight measurements)